

REVISIONS							
ZONE	LTR.	DESCRIPTION	DATE	ECN	BY	CKD	APVD
-	-	INITIAL RELEASE	11/30/06	-	-	-	-
-	A	EDITED VIEW TO ALIGN HOLES	11/30/07	082	MP	AA	WH

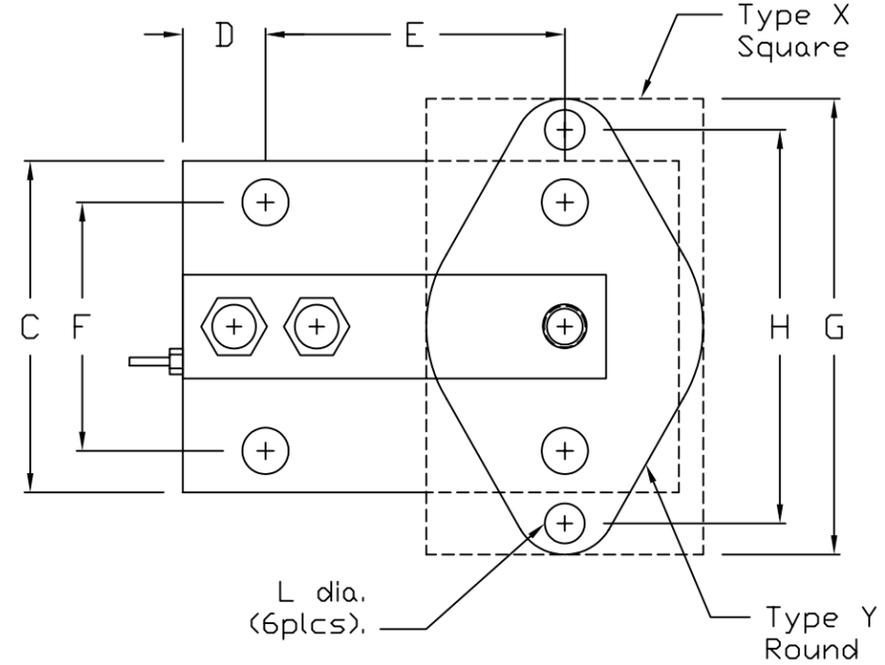
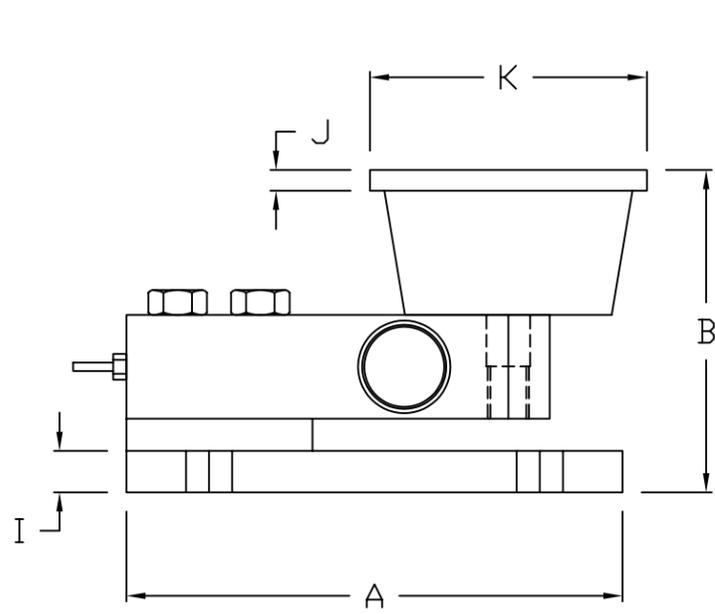

PERFORMANCE SPECIFICATIONS:

- CAPACITIES: 25LB, 50LB, 75LB, 100LB, 150LB, 250LB, 500LB, 1K, 1.5K, 2K, 2.5K, 4K, & 5KSE LB
- SAFE OVERLOAD: 150% FS
- FULL SCALE OUTPUT: 3.00 mV/V
- EXCITATION VOLTAGE: 10-15V AC/DC
- LOAD CELL RESISTANCE: 350 OHMS
- LOAD CELL CABLE: 4 CONDUCTOR, 20 FT
- OPERATING TEMPERATURE RANGE: -20°C - +60°C
- MATERIAL
LOAD CELL: ALLOY STEEL (NICKEL PLATED) OR STAINLESS STEEL
ASSEMBLY: STAINLESS STEEL

RATED CAPACITY	DIMENSIONS												
	A	B	C	D	E	F	G	H	I	J	K	L	TYPE
25LB-250LB	4.00	3.13	3.00	0.37	3.25	2.25	3.88	3.00	0.50	0.22	2.38	0.34	Y
500LB	6.00	3.88	4.00	1.00	4.00	3.00	5.50	4.13	0.50	0.25	3.38	0.56	Y
1K	6.00	4.00	4.00	1.00	4.00	3.00	5.13	4.13	0.50	0.25	3.00	0.56	X
1.5K-2.5K	6.00	4.00	4.00	1.00	4.00	3.00	6.25	5.00	0.50	0.38	4.62	0.56	X
4K-5KSE	6.00	4.50	4.00	1.00	4.00	3.00	6.25	5.00	1.00	0.38	4.62	0.56	X

DO NOT ALTER WITHOUT AGENCY NOTIFICATION

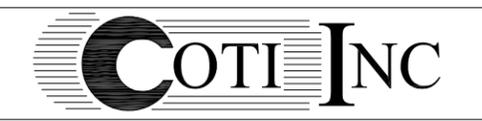

**MODEL CI 59M
TANK MOUNT**

APPROVALS		DATE
DRAWN:	MP	11/30/06
CHECKED:	AA	11/30/07
ENGINEER:	WH	11/30/07
APPROVED:	WH	11/30/07
MATERIAL		
SEE NOTES		

SCALE	SIZE	PART/DRAWING NO.	REV.
NONE	B	DOD-CI59M	A
MODEL CI59M		SHEET 1 OF 1	

THIS DOCUMENT CONTAINS PROPRIETARY INFORMATION AND SUCH INFORMATION MAY NOT BE REPRODUCED OR DISCLOSED FOR ANY PURPOSE OR USED TO PRODUCE THE ARTICLE OR SUBJECT WITHOUT WRITTEN PERMISSION FROM COTI, INC.

TOLERANCES UNLESS OTHERWISE SPECIFIED
.XX-±.01
.XXX-±.005
FRACTIONS-±1/16"
ANGLES: ±1/2"

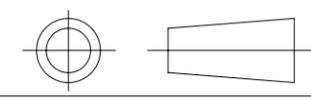

THIS DRAWING USES THIRD ANGLE PROJECTION

D
C
B
A

D
C
B
A

4
4
4
4

3
3
3
3

2
2
2
2

1
1
1
1